





swiss bed concept



# WOOD LINE

MASSIVHOLZ | BOIS MASSIF | SOLID WOOD

Achten Sie auf FSC®-zertifizierte Produkte | Soyez attentifs aux produits certifiés FSC® | Look for FSC®-certified products





# Bettrahmen | Cadre de lit | Bedframe



## Classic 16



**Breiten** | Largeurs | Widths:  
90, 100, 120, 140, 160, 180, 200 cm

**Längen** | Longueurs | Lengths: 190, 200, 210, 220 cm

**Einlegetiefe** | Hauteur encastrable | Insertion depth:  
16 cm

**Der Classic 16 Rahmen ist nicht in Eiche bright und Eiche brandy erhältlich.**

Le cadre Classic 16 n'est pas disponible en chêne bright et en chêne brandy.

The Classic 16 frame is not available in oak bright and oak brandy.

## Premium 18



**Breiten** | Largeurs | Widths:  
90, 100, 120, 140, 160, 180, 200 cm

**Längen** | Longueurs | Lengths:  
200, 210, 220 cm

**Einlegetiefe** | Hauteur encastrable | Insertion depth:  
18 cm

## Premium 23



**Breiten** | Largeurs | Widths:  
140, 160, 180, 200 cm

**Längen** | Longueurs | Lengths:  
200, 210, 220 cm

**Einlegetiefe** | Hauteur encastrable | Insertion depth:  
18\*, 23 cm

## Ausführungen | Exécutions | Executions

### Holz | Bois | Wood



**06**  
**Buche natur, lackiert**  
Hêtre naturel, laqué  
Natural beech, lacquered



**07**  
**Buche schoko, lackiert**  
Hêtre teinté chocolat, laqué  
Beech chocolate coloured, lacquered

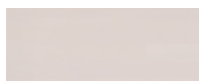

**09**  
**Buche weiss lasiert, lackiert**  
Hêtre teinté blanc lasuré, laqué  
Beech white stained, lacquered



**74**  
**Eiche bright, geölt**  
Chêne bright, huilé  
Oak bright, oiled



**76**  
**Eiche brandy, geölt**  
Chêne brandy, huilé  
Oak brandy, oiled



**80**  
**Kernbuche natur, geölt**  
Hêtre cœur rouge naturel, huilé  
Heart beech natural, oiled

# Traversen | Traverses | Bars

**Wir empfehlen grundsätzlich den Einsatz von Crosstraver (Quertraverse) oder Midtraver (Längstraverse).**

Nous recommandons en général l'utilisation de Crosstraver (traverse transversale) ou Midtraver (traverse centrale).

We recommend basically the insertion of Crosstraver (central cross bar) or Midtraver (central bar).



## Crosstraver

Quertraverse | Traverse transversale | Central cross bar

**Für alle Bettbreiten** | Pour toutes les largeurs de lit | For all bed widths



## Crosstraver-Twin

Quertraversen | Traverses transversales | Cross bars

**Für alle Bettbreiten** | Pour toutes les largeurs de lit | For all bed widths



## Midtraver

Längstraverse | Traverse centrale | Central bar

**Für Betten ab Breite 140 cm mit 2 Lattenrosten oder Motorrahmen-einbau** | Pour les lits à partir de 140 cm de largeur avec 2 sommiers ou l'installation d'un cadre motorisé | For beds from 140 cm width with 2 slats or motor frame installation



## Crosstraver-XXL

Quertraversen | Traverses transversales | Cross bars

**Für alle Bettbreiten** | Pour toutes les largeurs de lit | For all bed widths

**Übersicht Kompatibilität Traversen siehe Seite 2.12** | Aperçu compatibilité traverses voir page 2.12 | Overview compatibility bars see page 2.12

## \* Premium 23

**Bei der Einlegetiefe 18 cm sind die Füße/Sockel um 5 cm versenkt und um diese Höhe weniger sichtbar.**

Avec les équerres en position haute (18 cm) les pieds/socle sont encastrés de 5 cm sous le cadre et donc moins visibles.

With the insertion depth 18 cm the feet/socket are sunken in by 5 cm and this height less visible.

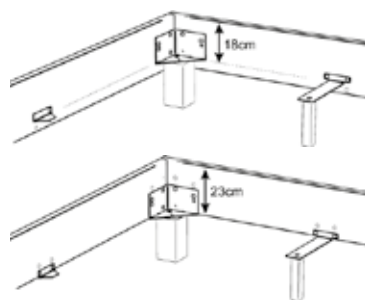

## Option Midtraver-move

**Achtung: nicht bei Füßen in der Höhe 30 cm, Lovie-Box und Practico-Box einsetzbar**

Attention : ne s'applique pas aux pieds à une hauteur de 30 cm, Lovie-Box et Practico-Box

Attention: not applicable for feet at a height of 30 cm, Lovie-Box and Practico-Box

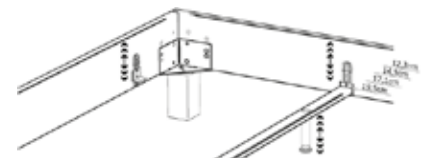

## Modern, einzigartig, wertbeständig

Unsere Wood-Line ist ebenso langlebig wie das Holz, aus dem es gemacht ist und bietet Schlafkomfort auf hohem Niveau: modern, zeitlos und wertbeständig. Natürlich gewachsene Unregelmäßigkeiten in Farbe, Maserung und Oberfläche schenken dem massiven Holz und den Möbeln dieser Linie einen sehr natürlichen und einzigartigen Charakter.

## Moderne, unique, de valeur stable

Le concept Wood-Line est aussi durable que le bois dont il est fait et offre un grand confort de sommeil : moderne, intemporel et durable. Les irrégularités naturelles de couleur, de grain et de surface donnent au bois massif et aux meubles de cette ligne un caractère très naturel et unique.

## Modern, unique, stable in value

The Wood-Line concept is just as durable as the wood it is made of and offers a high level of sleeping comfort: modern, timeless and of lasting value. Naturally grown irregularities in colour, grain and surface give the solid wood and furniture of this line a very natural and unique character.

# Füsse | Pieds | Feet

Holz | Bois | Wood



**Amigo**



**Lana**



**Cantu**



**Ivio**



**Juve**



**Masi**



**Massa**



**Evio**



**Practico-Box**



**Vilo**



**Lovie-Box**

90–140 (1 Schublade/Tiroir/Drawer)



**Lovie-Box**

140–200 (2 Schubladen/Tiroirs/Drawers)



**Standard:** gedämpfter Selbstzug  
Blumotion von BLUM

**Option:** Tip-On-Öffnung mit Vollauszug von BLUM

**Standard:** système d'amortissement  
Blumotion de BLUM

**Option:** ouverture Tip-On avec sortie totale de BLUM

**Standard:** soft closing runner Blumotion of BLUM

**Option:** opening Tip-On with full extension of BLUM

Holz | Bois | Wood

	Masse cm Dim. cm	Breiten cm Largeurs cm Widths cm	Höhen cm Hauteurs cm Heights cm				Holzfarben Couleurs bois Colours wood											
			10	20	25	30	06	07	09	10	16	74	76	80				
Amigo*	10×10			14														
Lana																		
Cantu	8×8																	
Evio		90–200																
Ivio	10×10																	
Juve	8×8																	
Masi	6×5,5																	
Lovie-Box** (1 Schublade/Tiroir/Drawer)		90–140																
Lovie-Box** (2 Schubladen/Tiroirs/Drawers)		140–200																
Massa**	16×16																	
Practico-Box (inkl. Boden   fond inclus   bottom included)		90–200																
Vilo		90–200																

**Practico-Box aus MDF ummantelt. Holzfüsse sind aus Massivholz |** Practico-Box en mdf laminié. Pieds en bois massif | Practico-Box in mdf coated. Wooden feet are of solid wood.  
\* nur mit Classic 16 Rahmen möglich | uniquement possible avec cadre Classic 16 | only possible with frame Classic 16

\*\*bei Premium 23 nur Einlegetiefe 23 cm möglich | pour Premium 23 uniquement possible avec hauteur encastrable de 23 cm | for Premium 23 only possible with insertion depth of 23 cm



**06**  
**Buche natur, lackiert**  
Hêtre naturel, laqué  
Natural beech, lacquered



**07**  
**Buche schoko, lackiert**  
Hêtre teinté chocolat, laqué  
Beech chocolate coloured, lacquered

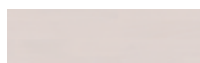

**09**  
**Buche weiss lasiert, lackiert**  
Hêtre teinté blanc lasuré, laqué  
Beech white stained, lacquered

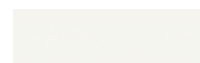

**10**  
**Buche weiss deckend, lackiert**  
Hêtre blanc couvrant, laqué  
Beech white covered, lacquered



**16**  
**Buche anthracit deckend, lackiert**  
Hêtre anthracite couvrant, laqué  
Beech anthracite covered, lacquered



**74**  
**Eiche bright, geölt**  
Chêne bright, huilé  
Oak bright, oiled



**76**  
**Eiche brandy, geölt**  
Chêne brandy, huilé  
Oak brandy, oiled



**80**  
**Kernbuche natur, geölt**  
Hêtre coeur rouge naturel, huilé  
Heart beech natural, oiled

# Füsse | Pieds | Feet

Metall | Métal | Metal

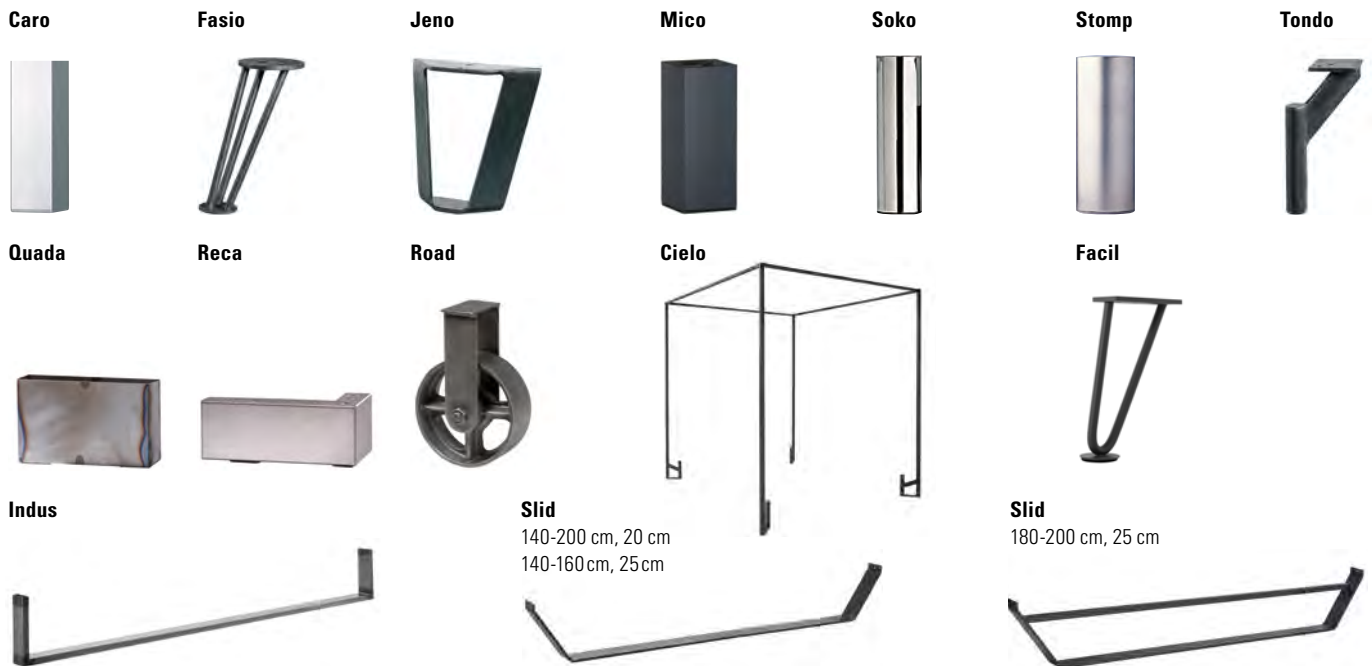

Metall | Métal | Metal

	Masse cm Dim. cm	Breiten cm Largeurs cm Widths cm	Höhen cm Hauteurs cm Heights cm				Metallfarben Couleurs métal Colours metal								
			10	20	25	30	00	04	10	16	40	41	42	43	45
Caro	6×6			●	●		●				●			●	
Cielo <sup>▲</sup>		120-200		●					●						
Facil				●											
Fasio	∅ 5/9			●						●		●			
Indus	6×2	140-200		●	●										●
Jeno	12×5		●	●	●				●						
Mico	8×8		●	●	●	●		●				●	●	●	
Quada	20×6,5			●	●										●
Reca	24×12		●										●		
Road*	∅ 13			●					●						
Slid	8/1	140-200		●	●					●				●	
Soko	∅ 6			●	●			●						●	
Stomp	∅ 8		●	●	●	●		●						●	
Tondo	∅ 3,5			●										●	

\* Füsse fixiert, Rollen nur optisch | Pieds fixes, roulettes uniquement décoratives | Feet fixed, castors only visual

<sup>▲</sup> Curty Vorhang und Vela Baldachin-Tuch siehe Register 2, Seite 12 | Curty rideau et Vela tissu de baldachin voir registre 2, page 12 | Curty curtain and Vela canopy cloth see index 2, page 12

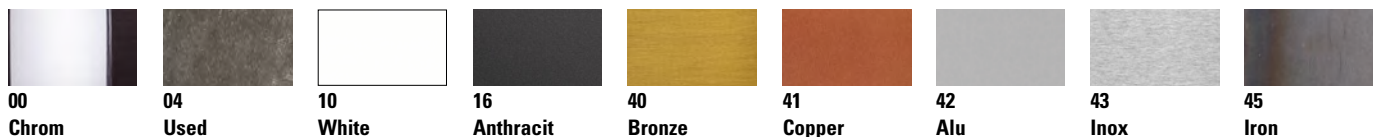

00 Chrom = Edelstahl poliert | Acier inoxydable poli | Stainless steel polished

04 Used = Stahl galvanisiert | Acier galvanisé | Steel galvanised

10 White = Stahl pulverbeschichtet | Acier thermolaqué | Steel powder-coated

16 Anthracit = Stahl pulverbeschichtet | Acier thermolaqué | Steel powder-coated

40 Bronze = Stahl lackiert | Acier laqué | Steel lacquered

41 Copper = Stahl lackiert | Acier laqué | Steel lacquered

42 Alu = Stahl pulverbeschichtet | Acier thermolaqué | Steel powder-coated

43 Inox = Edelstahl geschliffen | Acier inoxydable poncé | Stainless steel ground

45 Iron = Stahl geflammt, pulverbeschichtet | Acier flammé, thermolaqué | Steel mottled, powder-coated



# Bettkasten mit Holzkufe | Tiroirs de lit avec patins en bois | Bed drawers with wooden vat

**Lovie-Box + Covero**  
90-140 cm 1 Schublade | 1 Tiroir | 1 Drawer

**Stauraum** | Compartiment de rangement | Storage space: 134 × 61 × 16 cm

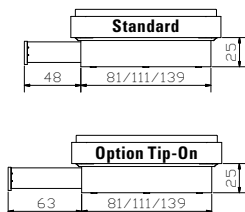

**Lovie-Box + Saceto**  
140-200 cm 2 Schubladen | 2 Tiroirs | 2 Drawers

**Stauraum** | Compartiment de rangement | Storage space: 2 × 134 × 61 × 16 cm

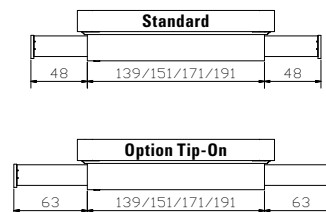

**Standard:** gedämpfter Selbsteinzug Blumotion von BLUM | système d'amortissement Blumotion de BLUM | soft closing runner Blumotion of BLUM

**Option:** Tip-On-Öffnung mit Vollauszug von BLUM | ouverture Tip-On avec sortie totale de BLUM | opening Tip-On with full extension of BLUM

## Roll-Box 20/25



Bettkasten in weiss oder anthrazit (Boden weiss)

### Voraussetzung

Bettfusshöhe von mindestens 20 cm erforderlich

### Optionen

Deckel Covero in weiss, Stoffabdeckung Saceto in Polyester grau.

## Roll-Box 20/25 + Cover



Tiroir de lit en blanc ou anthracite (fond blanc)

### Condition préalable

Une hauteur de pieds de lit d'au moins 20 cm est nécessaire

### Options

Couvercle Covero en blanc, tissu de protection Saceto en polyester gris.

## Roll-Box 20/25 + Saceto



Bed drawer in white or anthracite (bottom white)

### Condition

Feet of bed need a minimum height of 20 cm

### Options

Cover Covero in white, tissue of protection Saceto in polyester grey.



### Roll-Box 20

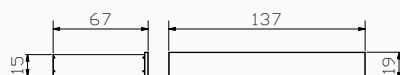

### Roll-Box 25

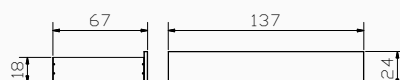

### Stauraum | Espace de rangement | Storage space

Roll-Box 20	=	134 × 61 × 13 cm
Roll-Box 25	=	134 × 61 × 16 cm

# Bettkasten | Coffres à literie | Bedding boxes

## Practico-Box + Classic 16 + Ultrafree-Lift KF



## Ultrafree-Lift KF

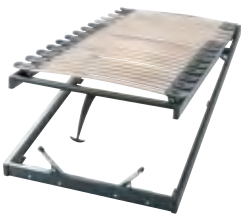

Box = inkl. Boden, Anwendung siehe Seiten 6.40/41  
**zu Practico-Box:**  
 Lattenrost **Ultrafree-Lift KF**  
 Kopf-/Fussverstellung  
 Rahmenholme Höhe 7 cm und 28 Federleisten  
 aus Buchenschichtholz  
 Gesamthöhe 11 cm

Lattenrost **Econom-move**  
 Unverstellbar  
 Rahmenholme Höhe 6 cm und 28 Federleisten  
 aus Buchenschichtholz  
 Gesamthöhe 9 cm

inkl. Gasdruckfedern und allen Beschlägen

**Details zu Ultrafree-Lift KF und Econom-move**  
 siehe Register 14, Seite 14.8

## Practico-Box + Premium 23 + Econom-move



## Econom-move



Box = fond inclus, utilisation voir pages 6.40/41  
**pour box Practico:**  
 Sommier **Ultrafree-Lift KF**  
 Tête et pied réglables  
 Cadre, hauteur 7 cm et 28 lattes en hêtre multiplis  
 Hauteur totale 11 cm

Sommier **Econom-move**  
 Non réglable  
 Cadre, hauteur 6 cm et 28 lattes en hêtre multiplis  
 Hauteur totale 9 cm

Pistons à gaz et toute la quincaillerie inclus

**Détails pour Ultrafree-Lift KF et Econom-move**  
 voir registre 14, page 14.8

## Stauraum | Compartiment de rangement | Storage space

90 × 200/210/220	=	81 × 190/200/210 × 24 cm
100 × 200/210/220	=	91 × 190/200/210 × 24 cm
120 × 200/210/220	=	111 × 190/200/210 × 24 cm
140 × 200/210/220	=	131 × 190/200/210 × 24 cm
160 × 200/210/220	=	74 × 190/200/210 × 24 (2 x) cm
180 × 200/210/220	=	84 × 190/200/210 × 24 (2 x) cm
200 × 200/210/220	=	94 × 190/200/210 × 24 (2 x) cm

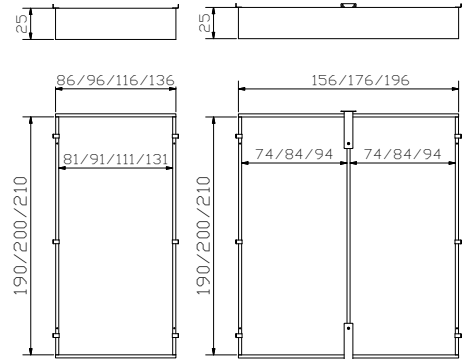

Box = bottom incl., handling see pages 6.40/41  
**for Practico-box:**  
 Slats **Ultrafree-Lift KF**  
 Head/footpiece adjustable  
 Frame, height 7 cm and 28 slats are of beech veneer board  
 Total height 11 cm

Slats **Econom-move**  
 Not adjustable  
 Frame, height 6 cm and 28 slats are of beech veneer board  
 Total height 9 cm

Pneumatic compression spring and all fittings included

**Details for Ultrafree-Lift KF and Econom-move**  
 see index 14, page 14.8

# Himmelbett ohne Grenzen

Lit à baldachin sans frontières | Canopy bed without borders

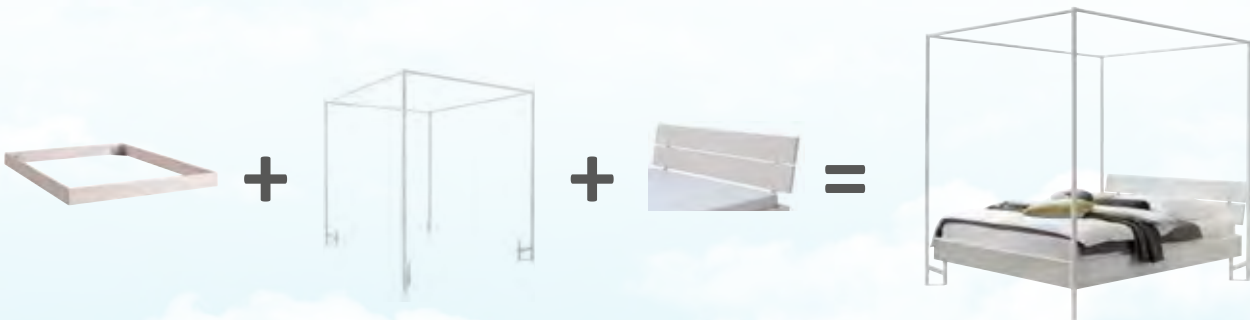

**Bettrahmen** | Cadre de lit | Bedframe

**Cielo**  
 Baldachin | Baldaquin | Canopy

**Kopfteil** | Tête de lit | Headboard

# Kopfteile | Têtes de lit | Headboards



## Dia



Dimension: 90/100, 120, 140, 160, 180/200

## Duetto



Dimension: 90/100, 120, 140, 160, 180, 200

## Lara



Dimension: 140, 160, 180, 200

## Litto

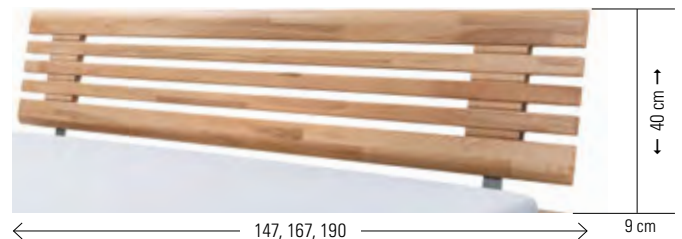

Dimension: 140, 160, 180/200

## Sandro



Dimension: 90/100, 120, 140, 160, 180, 200

## Varus



Dimension: 140, 160, 180, 200

## Vola



Dimension: 90/100, 120, 140, 160, 180, 200

## Kopfteil | Têtes de lit | Headboard

### Holzfarben

Couleurs bois

Colours wood

	06	07	09	74	76	80
Dia	●	●	●			●
Duetto	●	●	●	●	●	●
Litto	●	●	●			●
Lara	●	●	●	●	●	●
Sandro	●	●	●	●	●	●
Varus	●	●	●	●	●	●
Vola			●	●	●	●

## Holz | Bois | Wood



**06 Buche natur, lackiert**  
Hêtre naturel, laqué  
Natural beech, lacquered



**07 Buche schoko, lackiert**  
Hêtre teinté chocolat, laqué  
Beech chocolate coloured, lacquered

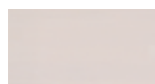

**09 Buche weiss lasiert, lackiert**  
Hêtre teinté blanc lasuré, laqué  
Beech white stained, lacquered



**74 Eiche bright, geölt**  
Chêne bright, huilé  
Oak bright, oiled



**76 Eiche brandy, geölt**  
Chêne brandy, huilé  
Oak brandy, oiled



**80 Kernbuche natur, geölt**  
Hêtre cœur rouge naturel, huilé  
Heart beech natural, oiled

# Kissen zu Kopfteilen | Coussins pour têtes de lit | Cushions for headboards

**Arona + Duetto**



**Lumo + Duetto**



**Ravo + Varus**



**Suny + Litto**



**Befestigung mit 2 Bändern (Klettverschluss)**

Fixation avec 2 bandes (Velcro®)

Fixation with 2 ribbons (Velcro®fastener)

**Varo + Varus**



**Stoffauswahl/Farben für Kissen siehe Register 1, Seiten 6–7**

Choix de tissus/couleurs pour coussins voir registre 1, pages 6–7

Choice of tissues/colours for cushions see index 1, pages 6–7



**Gepolsterte Kopfteile, Wandpaneele, Stoffauswahl/Farben siehe Register 1, Leselampen siehe Register 2.**

Têtes de lits rembourrées, panneaux muraux, choix de tissus/couleurs voir registre 1, lampes de lecture voir registre 2.

Upholstered headboards, wallpanels, choice of tissues/colours see index 1, reading lamps see index 2.

**Kissen | Coussins | Cushions**

**Effektive Masse cm**

Dimensions effectives cm  
Effective dimensions cm

Arona	86, 116, 136, 156, 176×3,5×25
Lumo	86, 116, 136, 156, 176×6×25
Suny (2er Set   set de 2   set of 2)	55×6×40
Ravo	80, 110, 130, 150, 170, 190×3,5×35
Varo (2er Set   set de 2   set of 2)	55×10×35

**zu Kopfteilen**

pour têtes de lit  
for headboards

	Duetto	Dia	Lara	Litto	Varus
●	●	●			
●	●	●			
●	●	●	●	●	●
●	●	●	●	●	●
●	●	●		●	●

**Breitenmasse cm**

Dimensions de largeur cm  
widths dimensions cm

90/100, 120, 140, 160, 180/200
90/100, 120, 140, 160, 180/200
90/100, 120, 140, 160, 180, 200

**Adapter | Adaptateur | Adapter**

**Bei hohen Matratzen kann mit dem Verlängerungsadapter das Kopfteil um 9 oder 13 cm erhöht werden.**

La tête de lit peut être rehaussée de 9 ou 13 cm avec l'adaptateur quand le matelas est plus épais.

With the extension adapter the headboard can be extended 9 or 13 cm if mattresses are high.

**Alu für alle Holzfarben, ausser 74 und 76. Black für Holzfarben 74 und 76.**

Alu pour toutes les couleurs de bois, sauf 74 et 76. Black pour les couleurs de bois 74 et 76.

Alu for all wood colours except 74 and 76. Black for wood colours 74 and 76.

**Head-Plus**

Metall | Métal | Metal



alu

black

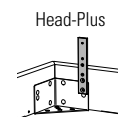
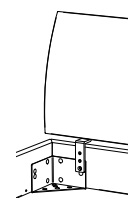

↑ +9 / +13 cm  
↓

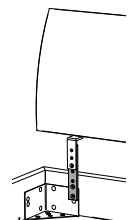

# Beimöbel | Accessoires | Accessories

**Caja**

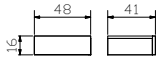

**Mido**

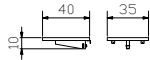

**\*Dupla**

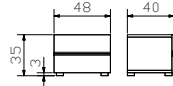

**\*Treva**

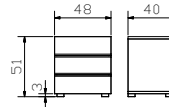

**\*Lovara**

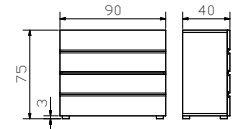

## Bank + Kissen | Banquette + Coussin | Bench + Cushion

**Sola**

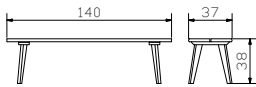

**Topia**

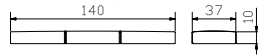

**Vano**

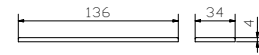

**Vano, Topia Bezugsstoffe siehe Register 1, Seiten 6-7**

Tissus de revêtement voir registre 1, pages 6-7

Cover fabrics see index 1, pages 6-7

## Herrendiener | Valet | Dressboy

**Claudio**

alu, anthracit, iron

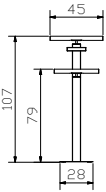
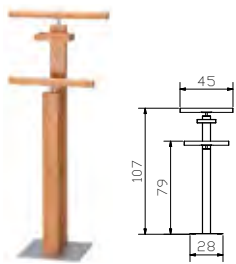

## Sekretär | Secrétaire | Bureau

**Aska**

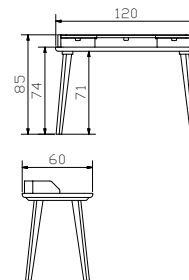

## Füsse | Pieds | Feet

**Leg 8**

alu



**Cila 10**

anthracit



**Jone 10**

anthracit, used



**Fuss Set (4 Stk.)** | Set de pieds (4 pcs) | Set of feet (4 pcs)  
Fuss passend zu Dupla, Treva und Lovara | Pied adapté à Dupla, Treva et Lovara | Foot suitable for Dupla, Treva and Lovara

### Holzfarben

Couleurs bois  
Colours wood

	06	07	09	10	74	76	80
Aska				●			●
Caja	●	●	●		●	●	●
Cila							
Claudio				●	●	●	●
Dupla	●	●	●		●	●	●
Jone							
Leg							
Lovara	●	●	●		●	●	●
Mido	●	●	●		●	●	●
Sola				●	●	●	●
Treva	●	●	●		●	●	●

### Metallfarben Füsse

Couleurs métal pieds  
Colours metal feet

	04	16	42	45
Aska				
Caja				
Cila		●		
Claudio		●	●	●
Dupla				
Jone	●	●		
Leg				
Lovara			●	
Mido				
Sola				
Treva				

## Holz | Bois | Wood



**06**  
**Buche natur, lackiert**  
Hêtre naturel, laqué  
Natural beech, lacquered



**07**  
**Buche schoko, lackiert**  
Hêtre teinté chocolat, laqué  
Beech chocolate coloured, lacquered



**09**  
**Buche weiss lasiert, lackiert**  
Hêtre teinté blanc lasuré, laqué  
Beech white stained, lacquered



**10**  
**Buche weiss deckend, lackiert**  
Hêtre blanc couvrant, laqué  
Beech white covered, lacquered



**74**  
**Eiche bright, geölt**  
Chêne bright, huilé  
Oak bright, oiled



**76**  
**Eiche brandy, geölt**  
Chêne brandy, huilé  
Oak brandy, oiled



**80**  
**Kernbuche natur, geölt**  
Hêtre coeur rouge naturel, huilé  
Heart beech natural, oiled



The mark of  
responsible forestry  
FSC® C123546

Look for FSC® certified products



# selezione

## 01

### MODELLAUSWAHL

Sélection du modèle | Model selection

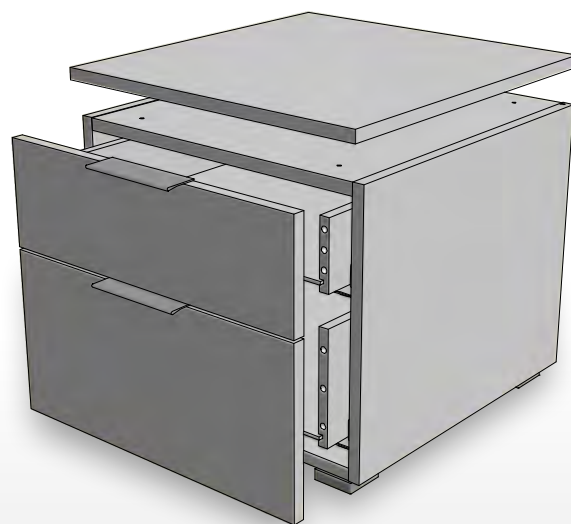

Twia



45/50/41 cm

Onia



45/50/41 cm

Owita



90/50/41 cm

Trio



45/50/55 cm

Dowe



45/50/55 cm

Dowio



90/50/55 cm

Quatro



45/50/86 cm

Unito



45/50/86 cm

Qunito



90/50/86 cm

Quatrine



90/50/86 cm

Portina



90/50/86 cm

Atrine



90/50/86 cm

Totrino



135/50/86 cm

Cassino



135/50/86 cm

Incentro



135/50/86 cm

Trequatri



135/50/86 cm

Stellen Sie sich Ihr Wunsch-Beimöbel nach Ihrem Geschmack zusammen: Der Korpus (Abb. 02), in zwei verschiedenen Farbvarianten, lässt sich zu den Front- und Top-Covern (Abb. 03) in acht Holz- und Farbausführungen kombinieren. Die Beimöbel können zerlegt oder teilmontiert bestellt werden. Bei zusammengesetzten Möbeln (z. B. Qunito, Incentro, ...) muss der Deckel noch montiert werden. Bei Kommoden mit Türen ist jeweils ein Einlegeboden vorhanden, Türöffnung nach links oder rechts möglich. Zusätzliche Böden sind erhältlich.

Composez le meuble d'appoint de vos rêves selon vos goûts : Le caisson (ill. 02), disponible en 2 variantes de couleurs, peut être combiné avec les façades et couvercles supérieurs (ill. 03) en 8 finitions de bois et de coloris. Les meubles d'appoint peuvent être commandés en kits ou assemblés. Pour les meubles assemblés (p. ex. Qunito, Incentro, ...) le couvercle doit encore être fixé. Les commodes avec portes sont équipées d'une étagère, ouverture de la porte possible à gauche ou à droite. Si besoin, des étagères supplémentaires sont disponibles.

Put together the side furniture you want according to your own taste: The body (fig. 02), in two different colour versions, can be combined with the front and top covers (fig. 03) in eight wood and colour versions. The furniture can be ordered disassembled or assembled. For assembled furniture (e.g. Qunito, Incentro, ...) the top cover must still be fitted. Chests of drawers with doors have one shelf, door opening possible to the left or right. Additional shelves are available.



**Kombinationsbeispiele und techn. Informationen**  
Exemples et informations  
Examples and informations



# 02

## KORPUS

Caisson | Body



# 03

## TOP/FRONT

Farben | Couleurs | Colours



# 04

## GRIFFE

Poignées | Handles



10 Weiss | Blanc | White



16 Anthracit | Anthracite



## FÜSSE

Pieds | Feet

### STANDARD



### OPTION

Leg 8 cm

Jone 10 cm

Cila 10 cm



alu



anthracit  
used



anthracit



10 Weiss | Blanc | White



16 Anthracit | Anthracite



### STANDARD



Alu

#### Griff zu Folienfronten

Poignée pour façades en mélaminé  
Handle for foil fronts



74 Eiche bright, geölt  
Chêne bright, huilé  
Oak bright, oiled



82 Nussbaum, geölt  
Noyer, huilé  
Walnut, oiled



76 Eiche brandy, geölt  
Chêne brandy, huilé  
Oak brandy, oiled



87 Wildbuche natur, geölt  
Hêtre nouveau naturel, huilé  
Wildbeech natural, oiled



80 Kernbuche natur, geölt  
Hêtre coeur rouge  
naturel, huilé  
Heart beech natural, oiled

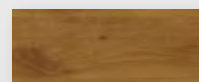

99 Wildeiche natur, geölt  
Chêne nouveau naturel, huilé  
Wildoak natural, oiled

### STANDARD



#### Holzgriff zu Holzfronten

Poignée en bois pour façades en bois  
Wooden handle for wooden fronts

### OPTION

Rivo



Used



Anthracit

#### Metallgriff zu Holzfronten

Poignée en métal pour façades en bois  
Metal handle for wooden fronts



The mark of  
responsible forestry  
FSC® C123546

Look for FSC® certified products