





swiss bed concept



# FINE LINE

MASSIVHOLZ | BOIS MASSIF | SOLID WOOD

Achten Sie auf FSC®-zertifizierte Produkte | Soyez attentifs aux produits certifiés FSC® | Look for FSC®-certified products





# Bettrahmen | Cadre de lit | Bedframe



## Syma 18

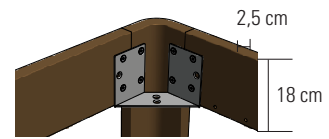

**Breiten** | Largeurs | Widths:  
90, 100, 120, 140, 160, 180, 200 cm

**Längen** | Longueurs | Lengths:  
190, 200, 210, 220 cm

**Einlegetiefe** | Hauteur encastrable | Insertion depth:  
18 cm

## Traversen | Traverses | Bars

**Wir empfehlen grundsätzlich den Einsatz von Crosstraver (Quertraverse) oder Midtraver (Längstraverse).**

Nous recommandons en général l'utilisation de Crosstraver (traverse transversale) ou Midtraver (traverse centrale).

We recommend basically the insertion of Crosstraver (central cross bar) or Midtraver (central bar).

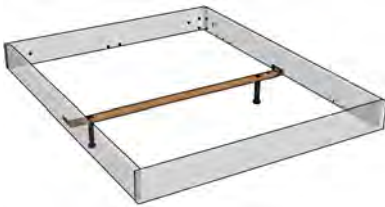

### Crosstraver

Quertraverse | Traverse transversale | Central cross bar

**Für alle Bettbreiten** | Pour toutes les largeurs de lit | For all bed widths



### Crosstraver-Twin

Quertraversen | Traverses transversales | Cross bars

**Für alle Bettbreiten** | Pour toutes les largeurs de lit | For all bed widths



### Midtraver

Längstraverse | Traverse centrale | Central bar

**Für Betten ab Breite 140 cm mit 2 Lattenrosten oder Motorrahmen-einbau** | Pour les lits à partir de 140 cm de largeur avec 2 sommiers ou l'installation d'un cadre motorisé | For beds from 140 cm width with 2 slats or motor frame installation



### Crosstraver-XXL

Quertraversen | Traverses transversales | Cross bars

**Für alle Bettbreiten** | Pour toutes les largeurs de lit | For all bed widths

**Übersicht Kompatibilität Traversen siehe Seite 2.12** | Aperçu compatibilité traverses voir page 2.12 | Overview compatibility bars see page 2.12

## Ausführungen | Exécutions | Executions

### Holz | Bois | Wood

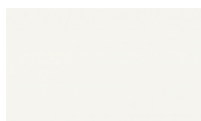

**10**  
**Buche weiss**  
**deckend, lackiert**

Hêtre blanc couvrant, laqué  
Beech white covered,  
lacquered

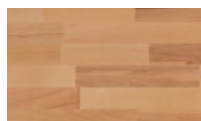

**80**  
**Kernbuche natur, geölt**  
Hêtre cœur rouge  
naturel, huilé  
Heart beech natural, oiled

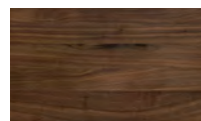

**82**  
**Nussbaum, geölt**  
Noyer, huilé  
Walnut, oiled

# Füsse | Pieds | Feet



Facito



Masito



Syko



Tondito



Ronda



Xylo



Lovie-Ron Box



90–140 (1 Schublade/Tiroir/Drawer)  
140–200 (2 Schubladen/Tiroirs/Drawers)

Practico-Ron Box



Airo



Eviron



Slitto



\*Cielo-Ron



\*Curty Vorhang und Vela Baldachin-Tuch siehe Seite 2.7

Curty rideau et Vela tissu de baldachin voir page 2.7  
Curty curtain and Vela canopy cloth see page 2.7

## Holz | Bois | Wood

	Breiten cm Largeurs cm Widths cm	Höhen cm Hauteurs cm Heights cm			Holzfarben Couleurs bois Colours wood			
		20	25	30	10	16	80	82
Airo	90–200	●	■		●	■	●	■
Eviron	90–200		●		●	●	●	■
Lovie-Ron Box (1 Schublade/Tiroir/Drawer)	90–140		●		●	●	●	■
Lovie-Ron Box (2 Schubladen/Tiroirs/Drawers)	140–200		●		●	●	●	■
Practico-Ron Box*	90–200		●		●	●	●	
Masito		●	●		●	■	●	●
Ronda		●	●	●	●	■	●	●
Xylo		●	●	●	●	■	●	●

Kufen und Boxfronten ausschliesslich in weiss oder anthrazit | Patins et façades box exclusivement en blanc ou en anthracite | Vats and box fronts in white or anthracite only

## Holz | Bois | Wood

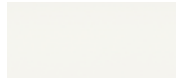

**10**  
Buche weiss deckend, lackiert  
Hêtre blanc couvrant, laqué  
Beech white covered, lacquered



**80**  
Kernbuche natur, geölt  
Hêtre cœur rouge naturel, huilé  
Heart beech natural, oiled

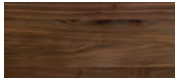

**82**  
Nussbaum, geölt  
Noyer, huilé  
Walnut, oiled



**16**  
Buche anthracit deckend, lackiert  
Hêtre blanc couvrant, laqué  
Beech white covered, lacquered

\*weiss/anthracit = MDF  
blanc/anthracite = MDF  
white/anthracite = MDF

## Metall | Métal | Metal

	Breiten cm Largeurs cm Widths cm	Höhen cm Hauteurs cm Heights cm			Metallfarben Couleurs métal Colours metal			
		20	25	30	00	10	16	42
Cielo-Ron <sup>▲</sup>	120–200	●	■			●	●	
Facito		●					●	
Syko		●	●	●	●			●
Slitto	140–200	●	●			●	●	●
Tondito		●					●	●

## Metall | Métal | Metal

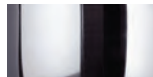

**00**  
Chrom

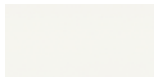

**10**  
White



**16**  
Anthracit



**42**  
Alu

**00 Chrom = Edelstahl poliert** | Acier inoxydable poli | Stainless steel polished  
**10 White = Stahl pulverbeschichtet** | Acier thermolaqué | Steel powder-coated  
**16 Anthracit = Stahl pulverbeschichtet** | Acier thermolaqué | Steel powder-coated  
**42 Alu = Stahl pulverbeschichtet** | Acier thermolaqué | Steel powder-coated

# Bettkasten mit Holzkufe | Tiroirs de lit avec patins en bois | Bed drawers with wooden vat

**Lovie-Ron Box + Covero**  
90-140 cm 1 Schublade | 1 Tiroir | 1 Drawer

**Stauraum** | Compartiment de rangement | Storage space: 134 × 61 × 16 cm

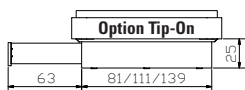
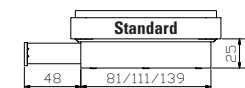

**Standard:** gedämpfter Selbsteinzug Blumotion von BLUM  
**Option:** Tip-On-Öffnung mit Vollauszug von BLUM

**Lovie-Ron Box + Saceto**  
140-200 cm 2 Schublade | 2 Tiroirs | 2 Drawers

**Stauraum** | Compartiment de rangement | Storage space: 2 × 134 × 61 × 16 cm

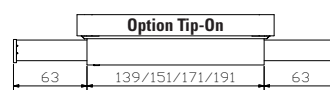
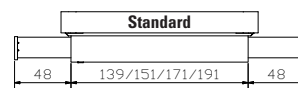

**Standard:** système d'amortissement Blumotion de BLUM  
**Option:** ouverture Tip-On avec sortie totale de BLUM

**Standard:** soft closing runner Blumotion of BLUM  
**Option:** opening Tip-On with full extension of BLUM

## Roll-Box 20/25



Bettkasten in weiss oder anthrazit (Boden weiss)

**Voraussetzung**  
Bettfusshöhe von mindestens 20 cm erforderlich

**Optionen**  
Deckel Covero in weiss, Stoffabdeckung Saceto in Polyester grau.

## Roll-Box 20/25 + Covero



Tiroir de lit en blanc ou anthracite (fond blanc)

**Condition préalable**  
Une hauteur de pieds de lit d'au moins 20 cm est nécessaire

**Options**  
Couvercle Covero en blanc, tissu de protection Saceto en polyester gris.

## Roll-Box 20/25 + Saceto



Bed drawer in white or anthracite (bottom white)

**Condition**  
Feet of bed need a minimum height of 20 cm

**Options**  
Cover Covero in white, tissue of protection Saceto in polyester grey.



### Roll-Box 20

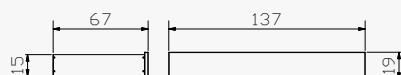

### Roll-Box 25

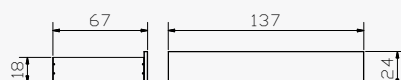

### Stauraum | Espace de rangement | Storage space

Roll-Box 20	=	134 × 61 × 13 cm
Roll-Box 25	=	134 × 61 × 16 cm

# Bettkasten | Coffres à literie | Bedding boxes

## Practico-Ron Box + Syma 18 + Ultrafree-Lift KF



## Ultrafree-Lift KF



Box = inkl. Boden, Anwendung siehe Seiten 8.18/19  
**zu Practico-Ron Box:**  
 Lattenrost **Ultrafree-Lift KF**  
 Kopf-/Fussverstellung  
 Rahmenholme Höhe 7 cm und 28 Federleisten  
 aus Buchenschichtholz  
 Gesamthöhe 11 cm

Lattenrost **Econom-move**  
 Unverstellbar  
 Rahmenholme Höhe 6 cm und 28 Federleisten  
 aus Buchenschichtholz  
 Gesamthöhe 9 cm

inkl. Gasdruckfedern und allen Beschlägen

**Details zu Ultrafree-Lift KF und Econom-move  
 siehe Register 14, Seite 14.8**

## Practico-Ron Box + Syma 18 + Econom-move



## Econom-move



Box = fond inclus, utilisation voir pages 8.18/19  
**pour box Practico-Ron :**  
 Sommier **Ultrafree-Lift KF**  
 Tête et pied réglables  
 Cadre, hauteur 7 cm et 28 lattes en hêtre multiplis  
 Hauteur totale 11 cm

Sommier **Econom-move**  
 Non réglable  
 Cadre, hauteur 6 cm et 28 lattes en hêtre multiplis  
 Hauteur totale 9 cm

Pistons à gaz et toute la quincaillerie inclus

**Détails pour Ultrafree-Lift KF et Econom-move  
 voir registre 14, page 14.8**

## Stauraum | Compartiment de rangement | Storage space

90 × 200/210/220	=	81 × 190/200/210 × 24 cm
100 × 200/210/220	=	91 × 190/200/210 × 24 cm
120 × 200/210/220	=	111 × 190/200/210 × 24 cm
140 × 200/210/220	=	131 × 190/200/210 × 24 cm
160 × 200/210/220	=	74 × 190/200/210 × 24 (2 x) cm
180 × 200/210/220	=	84 × 190/200/210 × 24 (2 x) cm
200 × 200/210/220	=	94 × 190/200/210 × 24 (2 x) cm

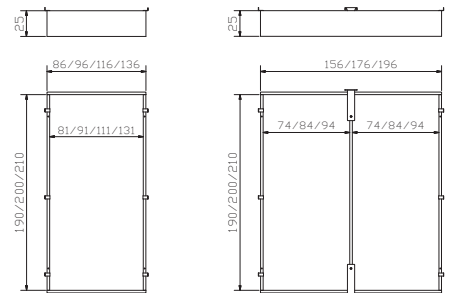

Box = bottom incl., handling see pages 8.18/19  
**for Practico-Ron box:**  
 Slats **Ultrafree-Lift KF**  
 Head/footpiece adjustable  
 Frame, height 7 cm and 28 slats are of beech veneer board  
 Total height 11 cm

Slats **Econom-move**  
 Not adjustable  
 Frame, height 6 cm and 28 slats are of beech veneer board  
 Total height 9 cm

Pneumatic compression spring and all fittings included

**Details for Ultrafree-Lift KF and Econom-move  
 see index 14, page 14.8**

# Himmelbett ohne Grenzen

Lit à baldachin sans frontières | Canopy bed without borders

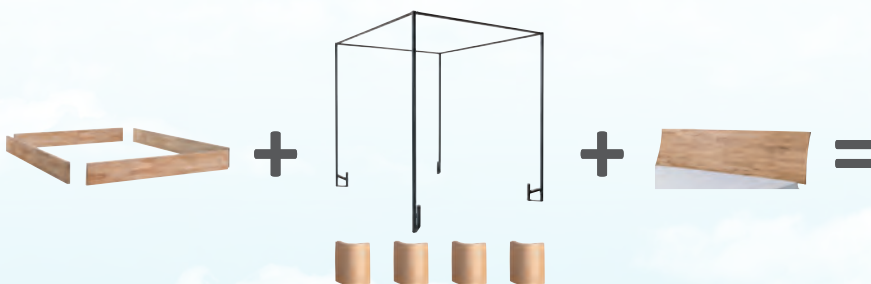

**Betrahmen**  
 Cadre de lit | Bedframe

**Cielo**  
 Baldachin | Baldaquin | Canopy

**Kopfteil**  
 Tête de lit | Headboard





# Kopfteile | Têtes de lit | Headboards



## Duetto



Dimension: 90/100, 120, 140, 160, 180, 200

## Varus



Dimension: 140, 160, 180, 200

## Vola



Dimension: 90/100, 120, 140, 160, 180, 200

## Adapter | Adaptateur | Adapter

**Bei hohen Matratzen kann mit dem Verlängerungsadapter das Kopfteil erhöht werden.** | La tête de lit peut être rehaussée avec l'adaptateur lorsque le matelas est plus épais. | With the extension adapter the headboard can be extended if mattresses are high.

**Head-Plus** (2er Set | set of 2 | set of 2)

**Metall** | Métal | Metal

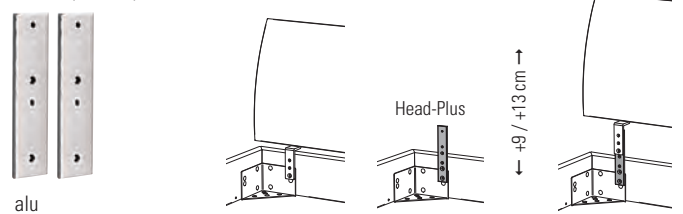

## gepolstert | rembourrées | upholstered

### Cemoo\*



Dimension: 90, 100, 120, 140, 160, 180, 200 (90–120 = 1 Kissen | Coussin | Cushion)

**Gewünschte Liegefläche (Länge)** = zu bestellende Bettrahmenlänge  
 Surface de couchage souhaitée (longueur) = longueur de cadre de lit à commander  
 Desired mattress lying area (length) = length of bedframe to be ordered

190	= 200
200	= 210
210	= 220

## Leselampe | Lampe de lecture | Reading lamp

**Leselampe bei Holz- und gepolsterten Kopfteilen montierbar**

La lampe de lecture peut être montée sur des têtes de lit en bois et rembourrées-  
 Reading lamp can be assembled on wooden an upholstered headboards

**Smart black** (2er Set | set of 2 | set of 2)



**Weitere Leselampen und technische Details siehe Register 2, Seite 2.11**

Autres lampes de lecture et détails techniques voir registre 2, page 2.11  
 Further reading lamps and technical details see index 2, page 2.11

**\*Das Kopfteil Cemoo enthält in Echtleder keine Teilungsnähte.**

En cuir véritable, la tête de lit Cemoo ne comporte pas de coutures de séparation.  
 The Cemoo headboard contains no dividing seams in genuine leather.

## Ausführungen | Exécutions | Executions

### Holz | Bois | Wood

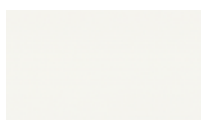

**10**  
**Buche weiss**  
**deckend, lackiert**  
 Hêtre blanc couvrant, laqué  
 Beech white covered,  
 lacquered



**80**  
**Kernbuche natur, geölt**  
 Hêtre cœur rouge  
 naturel, huilé  
 Heart beech natural, oiled

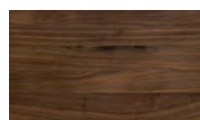

**82**  
**Nussbaum, geölt**  
 Noyer, huilé  
 Walnut, oiled

# Kissen zu Kopfteilen | Coussins pour têtes de lit | Cushions for headboards

**Arona + Duetto**



**Lumo + Duetto**



**Ravo + Varus**



**Suny + Varus**



**Varo + Varus**



## Befestigung mit 2 Bändern (Klettverschluss)

Fixation avec 2 bandes (Velcro®)

Fixation with 2 ribbons (Velcro® fastener)

## Stoffauswahl/Farben für Kissen siehe Register 1, Seiten 1.6–1.7

Choix de tissus/couleurs pour coussins voir registre 1, pages 1.6–1.7

Choice of tissues/colours for cushions see index 1, pages 1.6–1.7

## Alle Kissen in Echtleder haben Zier- sowie Teilungsnähte. Ausnahmen: Suny und Varo, diese Kissen haben lediglich Ziernähte.

Tous les coussins en cuir véritable ont des coutures décoratives et des coutures de séparation. A l'exception des coussins : Suny et Varo, ces coussins ont uniquement des coutures décoratives.

All cushions in genuine leather have decorative and dividing seams. Exceptions: Suny and Varo, these cushions only have decorative seams.

## Kissen | Coussins | Cushions

### Effektive Masse cm

Dimension effective cm  
Effective dimension cm

Arona	86, 116, 136, 156, 176×3,5×25
Lumo	86, 116, 136, 156, 176×6×25
Ravo	80, 110, 130, 150, 170, 190×3,5×35
Suny 2er Set   set de 2   set of 2	55×6×40
Varo 2er Set   set de 2   set of 2	55×10×35

### zu Kopfteilen

pour têtes de lit  
for headboards

Duetto	Varus
●	
●	
●	●
●	●
●	●

### Breitenmasse cm

Dimensions de largeur cm  
Widths dimensions cm

90/100, 120, 140, 160, 180/200
90/100, 120, 140, 160, 180/200
90/100, 120, 140, 160, 180, 200



# Beimöbel | Accessoires | Accessories

## Nachttische, Kommoden | Tables de nuit, commodes | Bedside tables, chests of drawers

Caja

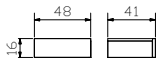

Noma

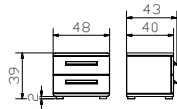

Trigo

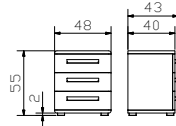

Sigma

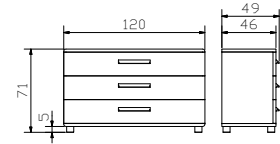

## Nachttische | Tables de nuit | Bedside tables / Sekretär | Secrétaire | Bureau / Herrendiener | Valet | Dressboy

Circo 44/52

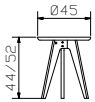

Lina

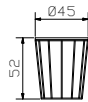

Nali

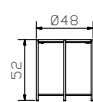

Aska

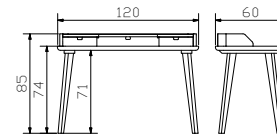

Claudio alu, anthracit, iron

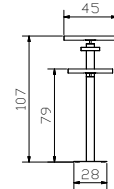

## Bank + Kissen | Banquette + Coussin | Bench + Cushion

Sola

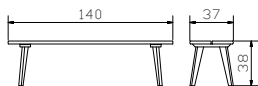

Topia

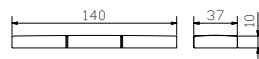

Vano

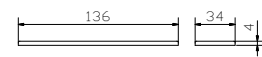

**Vano, Topia Bezugsstoffe siehe Register 1**

Tissus de revêtement voir registre 1

Cover fabrics see index 1

	Holzfarben Couleurs bois Colours wood			Metallfarben Couleurs métal Colours metal					Holzfarben Couleurs bois Colours wood			Metallfarben Couleurs métal Colours metal						
	10	80	82	04	16	40	41	42	45	10	80	82	04	16	40	41	42	45
Aska	●	●	●							●	●	●		●	●	●		
Caja	●	●	●															
Cila					●													
Circo	●	●	●															
Claudio	●	●	●		●			●	●					●				●
Jone				●	●													
Leg								●		●	●	●	●	●				
Lina	●	●	●											●	●	●		
Nali	●	●	●											●	●	●		
Noma	●	●	●															
Sigma	●	●	●															
Sima	●	●	●		●									●			●	●
Sola	●	●	●															
Trigo	●	●	●		●					●	●	●	●	●				

# Beimöbel | Accessoires | Accessories



**Füsse** | Pieds | Feet = Option zu | pour | for Noma, Trigo, Sigma  
Sima 10/20

**Leg 8** alu

**Jone 10** anthracit, used **Cila 10** anthracit



**Fuss Set (4 Stk.)** | Set de pieds (4 pcs.) | Set of feet (4 pcs.)

**Griffe** | Poignées | Handles

**Rivo** = Noma, Trigo, Sigma



Used



Anthracit



Bronze



Copper

**Ausführungen** | Exécutions | Executions

**Holz** | Bois | Wood

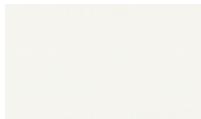

**10**  
**Buche weiss deckend, lackiert**  
Hêtre blanc couvrant, laqué  
Beech white covered, lacquered

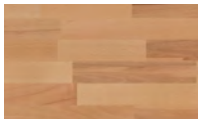

**80**  
**Kernbuche natur, geölt**  
Hêtre cœur rouge naturel, huilé  
Heart beech natural, oiled

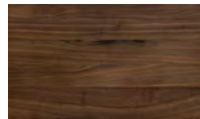

**82**  
**Nussbaum, geölt**  
Noyer, huilé  
Walnut, oiled



# selezione

## 01

### MODELLAUSWAHL

Sélection du modèle | Model selection

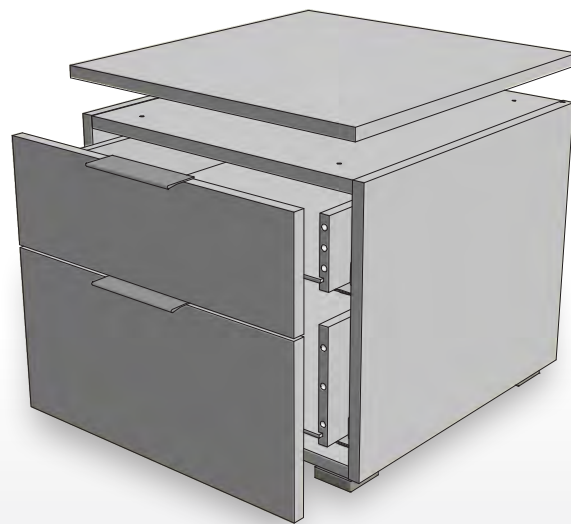

Twia



45/50/41 cm

Onia



45/50/41 cm

Owita



90/50/41 cm

Trio



45/50/55 cm

Dowe



45/50/55 cm

Dowio



90/50/55 cm

Quatro

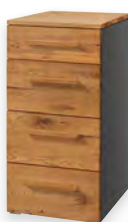

45/50/86 cm

Unito



45/50/86 cm

Qunito



90/50/86 cm

Quatrine



90/50/86 cm

Portina



90/50/86 cm

Atrine



90/50/86 cm

Totrino



135/50/86 cm

Cassino



135/50/86 cm

Incentro



135/50/86 cm

Trequatri



135/50/86 cm

Stellen Sie sich Ihr Wunsch-Beimöbel nach Ihrem Geschmack zusammen: Der Korpus (Abb. 02), in zwei verschiedenen Farbvarianten, lässt sich zu den Front- und Top-Covern (Abb. 03) in acht Holz- und Farbausführungen kombinieren. Die Beimöbel können zerlegt oder teilmontiert bestellt werden. Bei zusammengesetzten Möbeln (z. B. Qunito, Incentro, ...) muss der Deckel noch montiert werden. Bei Kommoden mit Türen ist jeweils ein Einlegeboden vorhanden, Türöffnung nach links oder rechts möglich. Zusätzliche Böden sind erhältlich.

Composez le meuble d'appoint de vos rêves selon vos goûts : Le caisson (ill. 02), disponible en 2 variantes de couleurs, peut être combiné avec les façades et couvercles supérieurs (ill. 03) en 8 finitions de bois et de coloris. Les meubles d'appoint peuvent être commandés en kits ou assemblés. Pour les meubles assemblés (p. ex. Qunito, Incentro, ...) le couvercle doit encore être fixé. Les commodes avec portes sont équipées d'une étagère, ouverture de la porte possible à gauche ou à droite. Si besoin, des étagères supplémentaires sont disponibles.

Put together the side furniture you want according to your own taste: The body (fig. 02), in two different colour versions, can be combined with the front and top covers (fig. 03) in eight wood and colour versions. The furniture can be ordered disassembled or assembled. For assembled furniture (e.g. Qunito, Incentro, ...) the top cover must still be fitted. Chests of drawers with doors have one shelf, door opening possible to the left or right. Additional shelves are available.



**Kombinationsbeispiele  
und techn. Informationen**  
Exemples et informations  
Exemples and informations



# 02

## KORPUS

Caisson | Body



# 03

## TOP/FRONT

Farben | Couleurs | Colours



# 04

## GRIFFE

Poignées | Handles



10 Weiss | Blanc | White



16 Anthracit | Anthracite



## FÜSSE

Pieds | Feet

### STANDARD



### OPTION

Leg 8 cm

Jone 10 cm

Cila 10 cm



alu



anthracit  
used



anthracit



10 Weiss | Blanc | White



16 Anthracit | Anthracite



### STANDARD



Alu

#### Griff zu Folienfronten

Poignée pour façades en mélaminé  
Handle for foil fronts

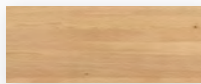

74 Eiche bright, geölt  
Chêne bright, huilé  
Oak bright, oiled

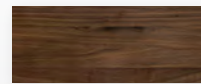

82 Nussbaum, geölt  
Noyer, huilé  
Walnut, oiled



76 Eiche brandy, geölt  
Chêne brandy, huilé  
Oak brandy, oiled



87 Wildbuche natur, geölt  
Hêtre nouveau naturel, huilé  
Wildbeech natural, oiled



80 Kernbuche natur, geölt  
Hêtre coeur rouge  
naturel, huilé  
Heart beech natural, oiled



99 Wildeiche natur, geölt  
Chêne nouveau naturel, huilé  
Wildoak natural, oiled

### STANDARD



#### Holzgriff zu Holzfronten

Poignée en bois pour façades en bois  
Wooden handle for wooden fronts

### OPTION

Rivo

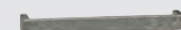

Used

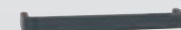

Anthracit

#### Metallgriff zu Holzfronten

Poignée en métal pour façades en bois  
Metal handle for wooden fronts



The mark of  
responsible forestry  
FSC® C123546

Look for FSC® certified products